



2010

TRUCK CHASSIS SPECIFICATIONS

All 2010 models require ultra-low sulfur diesel fuel

(NV8J) SS-NV038
GVW: 15,870 kg (35,000 lbs.)
ENGINE MODEL: J08E-TW (Turbo Intercooled)

DIMENSIONS (On standard specifications)

MODEL		NV8JLSA**	NV8JMSA**	NV8JTSA	NV8JVSA
Wheelbase	A mm(in.)	4,750 (187.0)	5,207 (205.0)	6,426 (253.0)	6,883 (271.0)
Overall length	B mm(in.)	7,686 (302.6)	8,143 (320.6)	9,921 (390.6)	9,921 (390.6)
Overall width	C mm(in.)	2,450 (96.5)	2,450 (96.5)	2,450 (96.5)	2,450 (96.5)
Overall height	D mm(in.)	2,715 (106.9)	2,715 (106.9)	2,715 (106.9)	2,715 (106.9)
Cab to axle	E mm(in.)	3,038 (119.6)	3,495 (137.6)	4,714 (185.6)	5,171 (203.6)
Rear overhang	F mm(in.)	1,905 (75.0)	1,905 (75.0)	2,464 (97.0)	2,007 (79.0)
Frame height at					
Front axle	G mm(in.)	935 (36.8)	935 (36.8)	935 (36.8)	935 (36.8)
Rear axle	H mm(in.)	1,025 (40.4)	1,025 (40.4)	1,025 (40.4)	1,025 (40.4)
Road clearance					
(at front axle)	J mm(in.)	255 (10.0)	255 (10.0)	255 (10.0)	255 (10.0)
Tread					
Front	K mm(in.)	2,015 (79.3)	2,015 (79.3)	2,015 (79.3)	2,015 (79.3)
Rear	L mm(in.)	1,835 (72.2)	1,835 (72.2)	1,835 (72.2)	1,835 (72.2)
Turning radius					
Tire	mm(in.)	7,690 (302.8)	8,350 (328.7)	10,120 (398.4)	10,790 (424.8)
Swept	mm(in.)	8,210 (323.2)	8,870 (349.2)	10,640 (418.9)	11,310 (445.3)

CHASSIS WEIGHTS (On std. spec., without spare tire & std. tool set)

MT	Total weight	kg(lb.)	4,755 (10,480)	4,810 (10,600)	4,935 (10,880)	4,960 (10,930)
	Front axle	kg(lb.)	2,865 (6,315)	2,910 (6,410)	2,990 (6,590)	3,040 (6,695)
	Rear axle	kg(lb.)	1,890 (4,165)	1,900 (4,190)	1,945 (4,290)	1,920 (4,235)
AT	Total weight	kg(lb.)	4,860 (10,710)	4,915 (10,840)	5,040 (11,110)	5,065 (11,170)
	Front axle	kg(lb.)	2,945 (6,490)	2,995 (6,605)	3,075 (6,780)	3,125 (6,895)
	Rear axle	kg(lb.)	1,915 (4,220)	1,920 (4,235)	1,965 (4,330)	1,940 (4,275)

** w/ 120,000 psi frame

POWER LINE & PERFORMANCE

[15,870 kg (35,000 lbs.) GVW & 11R22.5 tires]

Power line	<input type="checkbox"/> STD.	<input type="checkbox"/> OPT.
Max. speed km/h	121	119
Gradeability (tan.θ) %	35.6	45.8
Transmission Model	Eaton FS6406A	Allison 3000RDS
Type	Six-speed direct drive synchromesh 1st-6th	Six-speed automatic
1st.	9.008	3.487
2nd.	5.270	1.864
3rd.	3.220	1.409
Ratios	4th.	2.040
	5th.	1.361
	6th.	1.000
	Rev.	8.625
Rear axle gear ratios	4.110	5.630
Tire is combined with ratio	11R22.5	11R22.5

ENGINE

Model	HINO J08E-TW
Type:	Diesel 4-cy., 6-cyl. in-line, water-cooled
Combustion system:	Direct injection type
Max. output:	260HP at 2,500 rpm
Max. torque: (SAE Gross)	794 N·m (585 lb.-ft.) at 1,500 rpm
Bore and stroke:	112 x 130 mm (4.41 x 5.12 in.)
Piston displacement	7.680 L (468.8 cu.in.)
Fuel injection system:	Common rail ND
Governor:	Electronically controlled
Intake system:	Turbocharged and intercooled
Air cleaner:	Paper filter type ("DONALDSON")
Pre-heater:	Glow heater plug type
Fan clutch:	Bimetal thermostat sensor regulates fan speed
Block heater:	1,000 watts/120V immersion type

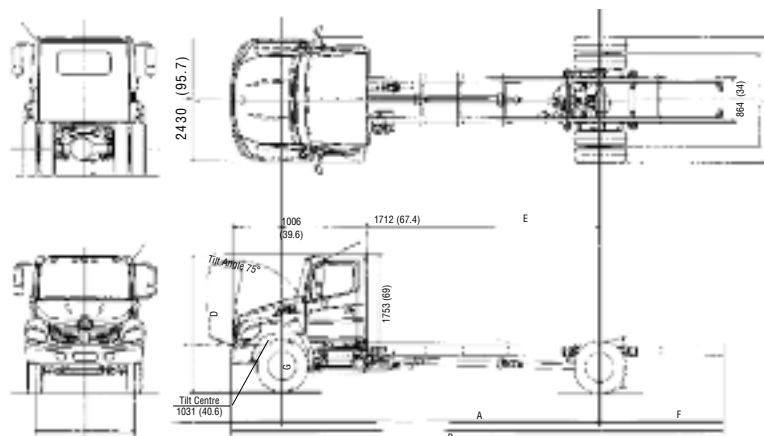

THE QUALITY CHOICE.

WEIGHT CAPACITIES

Front axle	kg(lbs.)	5,455 (12,000)
Rear axle	kg(lbs.)	10,455 (23,000)
Front spring	kg(lbs.)	5,455 (12,000)
Rear spring	kg(lbs.)	10,455 (23,000)

LIQUID CAPACITIES

Fuel tank ltr.(gal./US)	196.8 (52), aluminum
Cooling system	23.5 (6.21)
ltr.(gal./US)	: Eaton FS6406A
	23.0 (6.08)
	: ALLISON 3000RDS

AXLE / SUSPENSION

Front axle	MFS-12 series reversed Elliot, "I" beam; Oil-lubricated front wheel bearings
Front spring	Taper-leaf springs w/ shock absorbers
Rear axle	RS23-160 series Full-floating, single reduction Single-speed by hypoid gears
Rear spring	Semi-elliptic main and auxiliary helper-leaf spring
Option:	Two air bag suspension with shock absorbers and dump valve

FRAME (80,000 PSI)

Ladder type	Straight] section
Width mm(in.)	866.8 (34.1) : W/B: 253/271
Tensile strength	56.2 (79,935)
kg/mm ² (lb/in) ²	
Resisting bending	147.56 x 105 mm • kg
moment (one side)	(1,280,800)
kg•cm (in•lbs.)	no reinforcement

FRAME (120,000 PSI)

Ladder type	Straight] section
Width mm(in.)	866.8 (34.1) : W/B: 187/205
Tensile strength	87.8 (120,488)
kg/mm ² (lb/in) ²	
Resisting bending	231.79 x 105 mm • kg
moment (one side)	(1,933,200)
kg•cm (in•lbs.)	no reinforcement

STEERING

Type	Telescopic and tilt steering column with lock Recirculating ball, with hydraulic booster integral type
------	---

CLUTCH

Type	Dry single plate with damper springs and auto adjuster EATON-SPICER SAS1401 series
Facing material	Cerametallic
Facing outside diameter mm (in.)	350 (13.8)
Control	Hydraulic

WHEELS / TIRES

6 Wheels	22.5X8.25 10-stud disc.
6 Tires	11R22.5(G)
Brand & Pattern	BS Fr: RIB, Rr: LUG

BRAKES

Service brake	Full air, dual circuit, "S" cam type, leading & trailing shoes, with automatic adjustment
Drum diameter	Front;
x lining width	381 x 101.6 x 18.5
x thickness	(15 x 4 x 0.73)
mm(in.)	Rear;
	419.1 x 177.8 x 21.6
	(16.5 x 7 x 0.85)
Control	Full air dual circuit with Antilock Brake System (ABS)
Parking brake	Spring brake acting on rear wheels
Air dryer for air tank	Equipped with heater (Bendix)
Exhaust brake	Electric-pneumatic with valve in exhaust pipe

CAB EQUIPMENT

Cab construction	- All steel welded
Seating	- Three
Driver's seat	- Adjustable reclining, covered with fabric with air suspension
Passenger's seat	- Bench type, covered with fabric
Seat belts	- 3-point type (driver and passenger), one 2-point type (center)
Heater/Defroster	-18,357 BTU/h (4,627 Kcal/h)
Mirrors	outside rearview, chrome, 1 flat, heated and 1 convex on each side
Sun visors	- Two
Over-head console	- Two
Air conditioning	
Windshield	- Laminated
Windshield wipers	- Dual electric, 2-speed and intermittent
Cup holder	- dash and console mounted
Electric power windows	
Electronic cruise control	
Cigarette lighter / 12V power outlet	
Power door lock	

DASH INSTRUMENTATION

Meters and gauges, metric system	
Speedometer- km/h (mph)	
Odometer (km/h)	
Fuel gauge	
Coolant temperature gauge	
Engine tachometer	
Warning and pilot lamps and buzzers	
Oil pressure warning lamp and buzzer	
Brake pressure warning lamp and buzzer	
Coolant level warning lamp and buzzer	
Battery charging warning lamp	
High beam indicator lamp	
Turn signal pilot lamp	
Parking brake warning lamp	
Engine control system warning lamp	
ABS warning lamp	
Glow plug pre-heater indicator lamp	

ELECTRICAL EQUIPMENT

Batteries	Two, parallel connection, each 12 V
Capacity	1400 CCA
Alternator	105 A brushless
Starter	12 V, 4.8 kW
Audio system	AM/FM radio with CD
Headlamps	2, composite type
Identification lamps (front) LED type	
Stop/Tail lamps	
Back-up lamps	
Turn signals and hazard warning lamps	
Front side marker lamps	
Clearance lamps (front) LED type	
Air horn and dual electric horns	

CHASSIS EQUIPMENT

Fuel pre-filter	- Pre-filter (dust) and sedimenter (water) with heater - DAVCO
Reflectors	- Two rear, two front side
Hook	- One at front
Bumper	- Chrome
Radiator Grille	- Chrome

See your authorized Hino Dealer for a complete list of options and accessories.

NOTE : All specifications of the products are with normal manufacturing allowances and tolerances. HINO MOTORS CANADA, LTD. reserves the right to alter specifications at any time without previous notice.